



UL INTERNATIONAL (UK) LTD
 Kingsland Business Park,
 Unit 1-3 Horizon,
 Wade Rd,
 Basingstoke RG24 8AH,
 United Kingdom



designated according to Article 29 of the Regulation (EU) No 305/2011 and member of EOTA (European Organisation for Technical Assessment, www.eota.eu)

European Technical Assessment

ETA 13/0879
of 08/11/2019

Technical Assessment Body issuing the ETA and designated according to Article 29 of the Regulation (EU) No 305/2011: UL International (UK) Ltd

Trade name of the construction product

Protecta FR Acrylic

Product family to which the construction product belongs

Fire Stopping and Sealing Product:
 • Linear Joint and Gap Seals

Manufacturer

Polyseam Ltd
 15. St. Andrews Road
 Huddersfield,
 West Yorkshire
 HD1 6SB,
 UK

Manufacturing plant(s)

Polyseam Ltd
 15. St. Andrews Road
 Huddersfield,
 West Yorkshire
 HD1 6SB,
 UK

This European Technical Assessment contains

16 pages including 1 Annex which forms an integral part of this assessment.

This European Technical Assessment is issued in accordance with regulation (EU) No 305/2011, on the basis of

EAD 350141-00-1106, September 2017.

This version replaces

ETA 13/0879 issued on 17/11/2017

Translations of this European Technical Assessment in other languages shall fully correspond to the original issued document and should be identified as such.

Communication of this European Technical Assessment, including transmission by electronic means, shall be in full. However, partial reproduction may be made, with the written consent of the issuing Technical Assessment Body. Any partial reproduction has to be identified as such.

Table of Contents

I.	SPECIFIC PARTS OF THE EUROPEAN TECHNICAL ASSESSMENT	3
1	Technical description of the product	3
2	Specification of the intended uses of the product in accordance with the applicable European Assessment Document (Hereinafter EAD): EAD 350141-00-1106, September 2017	3
3	Performance of the product and references to the methods used for its assessment	5
4	ASSESSMENT AND VERIFICATION OF CONSTANCY OF PERFORMANCE (HEREINAFTER AVCP) SYSTEM APPLIED, WITH REFERENCE TO ITS LEGAL BASE	6
5	Technical details necessary for the implementation of the AVCP system, as provided for in the applicable EAD	6
6	Issued on:	7
	ANNEX A – Resistance to Fire Classification – Protecta FR Acrylic	8
A.1	Flexible wall constructions according to 2.1) with wall thickness of minimum 75 mm and minimum 1 x layer of 12.5 mm board per side	8
A.1.1	Linear joint seals, between head of flexible wall and soffit of concrete floor and vertical end of flexible wall and concrete wall	8
A.2	Flexible wall constructions according to 1.2.1 with wall thickness of minimum 100 mm and minimum 2 x layer of 12.5 mm board per side	9
A.2.1	Linear joint seals, between head of flexible wall and soffit of concrete floor and vertical end of flexible wall and concrete wall	9
A.2.2	Flexible wall construction with wall thickness of minimum 100 mm and timber substrates and architraves	10
A.2.2.1	Linear joint or gap seals, vertically or horizontal orientated with backing materials	10
A.2.3	Flexible wall construction with wall thickness of minimum 100 mm and timber substrates	11
A.2.3.1	Linear joint or gap seals, vertically or horizontal orientated with backing materials	11
A.2.4	Flexible wall construction with wall thickness of minimum 100 mm and steel substrates	12
A.2.4.1	Linear joint or gap seals, vertically or horizontal orientated with backing materials	12
A.2.5	Linear joint or gap seals, vertically or horizontal orientated with backing materials	13
A.3	Rigid wall constructions according to 1.2.1 with wall thickness of minimum 150 mm	14
A.3.1	Linear joint or gap seal, between head of rigid wall and soffit of concrete floor / between rigid walls	14
A.4	Rigid floor constructions according to 1.2.1 with floor thickness of minimum 150 mm	15
A.4.1	Linear joint or gap seal, between floor slabs or between floor slab and wall with sealant to the top face of the floor only	15
A.4.2	Linear joint or gap seals, in or between rigid floors	16

I. SPECIFIC PARTS OF THE EUROPEAN TECHNICAL ASSESSMENT

1 Technical description of the product

- 1) Protecta FR Acrylic is an intumescent acrylic sealant used to form linear gap seals where gaps are present in wall and floor constructions and linear joint seals where wall and floor constructions abut.
- 2) The Protecta FR Acrylic is supplied in liquid form contained within 310 & 380 ml cartridges and 600 ml foil packs. The sealant is gunned into the aperture in the separating element/elements and around the service or services, to a specified depth utilising a backing material.
- 3) Protecta FR Acrylic contains no carcinogenic substances or mutagenic substances, flame retardants or antimicrobiological agents.
- 4) Polyseam Ltd submitted a written declaration that Protecta FR Acrylic does not contain substances which have to be classified as dangerous according to Directive 67/548/EEC and Regulation (EC) No 1272/2008 and listed in the "Indicative list on dangerous substances" of the EGDS - taking into account the installation conditions of the construction product and the release scenarios resulting from there.

In addition to the specific clauses relating to dangerous substances contained in this European technical Assessment, there may be other requirements applicable to the products falling within its scope (e.g. transposed European legislation and national laws, regulations and administrative provisions). In order to meet the provisions of the Construction Products Regulation, these requirements need also to be complied with, when and where they apply.

- 5) The use category of Protecta FR Acrylic in relation to BWR 3 (Hygiene, health and environment) is IA1.

2 Specification of the intended uses of the product in accordance with the applicable European Assessment Document (Hereinafter EAD): EAD 350141-00-1106, September 2017

Detailed information and data is given in Annex A.

The intended use of system Protecta FR Acrylic is to reinstate the fire resistance performance of gaps in and joints in and between flexible wall and rigid wall constructions, gaps in and joints between rigid floor constructions.

- 1) The specific elements of construction that the system Protecta FR Acrylic may be used to provide a gap or joint seal in, are as follows:

Flexible walls: The wall must have a minimum thickness of 75 mm and comprise steel or wooden studs lined on both faces with minimum 1 layers of 12.5 mm thick boards. The wall is permitted with or without insulation material between the boards.

Rigid walls: The wall must have a minimum thickness of 75 mm and comprise concrete, aerated concrete or masonry, with a minimum density of 650 kg/m³.

Rigid floors: The floor must have a minimum thickness of 150 mm and comprise aerated concrete or concrete with a minimum density of 650 kg/m³.

The supporting construction must be classified in accordance with EN 13501-2 for the required fire resistance period.

- 2) The system Protecta FR Acrylic may be used to provide a linear joint or gap seal with specific supporting constructions and substrates (for details see Annex A).

Protecta Fire Protection Systems which involve linear seals on both sides of a flexible wall may also be used in the situation where the linear seal is on one side of the wall only and the remaining side of the wall is not punctured at the same point. All fire integrity and thermal insulation ratings for such single-sided linear seals remain the same as for the equivalent double-sided linear seal.

- 3) The maximum permitted joint/gap width for system Protecta FR Acrylic is 100 mm.
- 4) The maximum movement capability of system Protecta FR Acrylic is $\leq 7.5\%$ (not tested to EAD 350141-00-1106).
- 5) The provisions made in this European Technical Assessment are based on an assumed working life of the Protecta FR Acrylic of 30 years, provided that the conditions laid down in sections 4.2/5.1/5.2 for the packaging/transport/ storage/installation/use/repair are met. The indications given on the working life cannot be interpreted as a guarantee given by the producer, but are to be regarded only as a means for choosing the right products in relation to the expected economically reasonable working life of the works.
- 6) Type Z₂: Intended for uses in internal conditions with humidity lower than 85 % RH excluding temperatures below 0°C, without exposure to rain or UV.

3 Performance of the product and references to the methods used for its assessment

Product-type: Sealant		Intended use: Linear Joint & Gap Seal
Basic requirement for construction work	Essential characteristic	Performance
BWR 2 Safety in case of fire		
EN 13501-1	Reaction to fire	Class D-s1, d1
EN 13501-2	Resistance to fire	Annex A
BWR 3 Hygiene, health and environment		
Declaration of manufacturer & EN 16516	Content, emission and/or release of dangerous substances	Use categories: IA1 Declaration of manufacturer
EN 1026:2000	Air permeability (material property)	No performance determined
EAD 350141-00-1106, Annex C & EN 12390-8	Water permeability (material property)	No performance determined
BWR 4 Safety in use		
EOTA TR 001:2003	Mechanical resistance and stability	No performance determined
EOTA TR 001:2003	Resistance to impact/movement	No performance determined
EOTA TR 001:2003 ISO 11600 & EAD 350141-00-1106, Clause 2.2.13	Adhesion	No performance determined
EAD 350141-00-1106, Clause 2.2.12	Durability	Z ₂
EAD 350141-00-1106, Clause 2.2.13	Movement capacity	No performance determined
EAD 350141-00-1106, Clause 2.2.14	Cycling of perimeter seals for curtain walls	No performance determined
EAD 350141-00-1106, Clause 2.2.15	Compression set	No performance determined
EAD 350141-00-1106, Clause 2.2.16	Linear expansion on setting	No performance determined
BWR 5 Protection against noise		
EN 10140-1,2,4,5/ EN ISO 717-1	Airborne sound insulation	Rw(C;Ctr)= 62 (-1;-5) dB*
BWR 6 Energy economy and heat retention		
EN 12664, EN 12667, EN 12939, EN ISO 8990, EN ISO 6946, EN ISO 10456	Thermal properties	No performance determined
EN ISO 12572, EN 12086, EN ISO 10456	Water vapour permeability	No performance determined

* At 12 mm depth

4 ASSESSMENT AND VERIFICATION OF CONSTANCY OF PERFORMANCE (HEREINAFTER AVCP) SYSTEM APPLIED, WITH REFERENCE TO ITS LEGAL BASE

According to the decision 1999/454/EC – Commission Decision of date 22nd June 1999 on the procedure for attesting the conformity of construction products pursuant to Article 20(2) of Council Directive 89/106/EEC as regards fire stopping, fire sealing and fire protective products, published in the Official Journal of the European Union (OJEU) L178/52 of 14/07/1999, see <http://eur-lex.europa.eu/JOIndex.do> of the European Commission¹, as amended, the system(s) of assessment and verification of constancy of performance (see Annex V to Regulation (EU) No 305/2011) given in the following table(s) applies (apply).

Product(s)	Intended use(s)	Level(s) or class(es)	System(s)
Fire stopping and Fire Sealing Products	For fire compartmentation and/or fire protection or fire performance	Any	1

5 Technical details necessary for the implementation of the AVCP system, as provided for in the applicable EAD

Tasks of the manufacturer:

Factory production control

The manufacturer shall exercise permanent internal control of production. All the elements, requirements and provisions adopted by the manufacturer shall be documented in a systematic manner in the form of written policies and procedures, including records of results performed. This production control system shall ensure that the product is in conformity with this European technical Assessment.

The manufacturer may only use initial / raw / constituent materials stated in the technical documentation of this European Technical Assessment.

The factory production control shall be in accordance with the Control Plan of 5th January 2017 relating to the European technical assessment ETA 13/0879 issued on 08/11/2019 which is part of the technical documentation of this European technical approval. The "Control Plan" is laid down in the context of the factory production control system operated by the manufacturer and deposited at UL International (UK) Ltd.

The results of factory production control shall be recorded and evaluated in accordance with the provisions of the Control Plan.

¹ Official Journal of the European Communities L178/52 of 14/7/1999

Other tasks of the manufacturer

Additional information

The manufacturer shall provide a technical data sheet and an installation instruction with the following minimum information:

(a) Technical data sheet:

- Field of application:
- Building elements for which the linear joint seal or penetration seal is suitable, type and properties of the building elements like minimum thickness, density, and - in case of lightweight constructions – the construction requirements.
- Limits in size, minimum thickness etc. of the joint or penetration seal
- Construction of the linear joint seal or penetration seal including the necessary components and additional products (e.g. backfilling material) with clear indication whether they are generic or specific.
- Services which the penetration seal is suitable, type and properties of the services like material, diameter, thickness etc. in case of pipes including insulation materials; necessary/allowed supports/fixings (e.g. cable trays)

(b) Installation instruction:

- Steps to be followed
- Procedure in case of retrofitting
- Stipulations on maintenance, repair and replacement

6 Issued on:

8th November 2019

Report by:



D. Yates
Project Engineer
Building and Life Safety Technologies

Reviewed by:



C. Johnson
Staff Engineer
Building and Life Safety Technologies

For and on behalf of UL International (UK) Ltd.

ANNEX A – Resistance to Fire Classification – Protecta FR Acrylic

A.1 Flexible wall constructions according to 2 1) with wall thickness of minimum 75 mm and minimum 1 x layer of 12.5 mm board per side

A.1.1 Linear joint seals, between head of flexible wall and soffit of concrete floor and vertical end of flexible wall and concrete wall

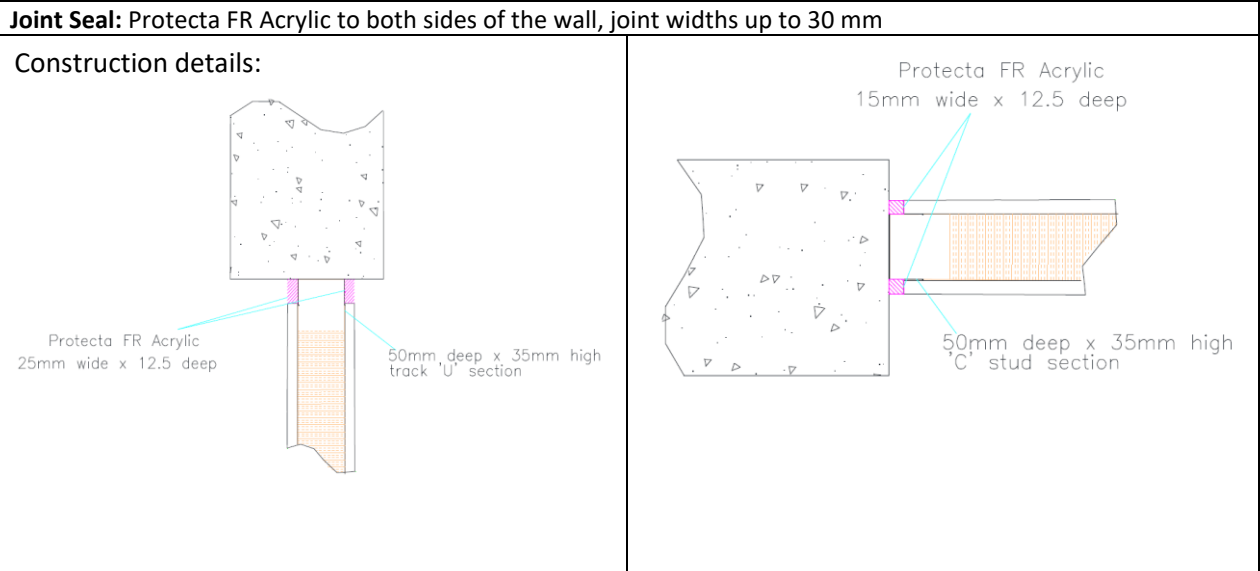

A.1.1.1

Substrate	Depth (mm)	Backing (minimum)	Classification
Plasterboard / concrete	12.5 min.	50 mm steel partition head track/ stud	E 60 – T – X – F – W 25 EI 45 – T – X – F – W 25
			E 60 – V – X – F – W 15 EI 45 – V – X – F – W 15

A.2 Flexible wall constructions according to 1.2.1 with wall thickness of minimum 100 mm and minimum 2 x layer of 12.5 mm board per side

A.2.1 Linear joint seals, between head of flexible wall and soffit of concrete floor and vertical end of flexible wall and concrete wall

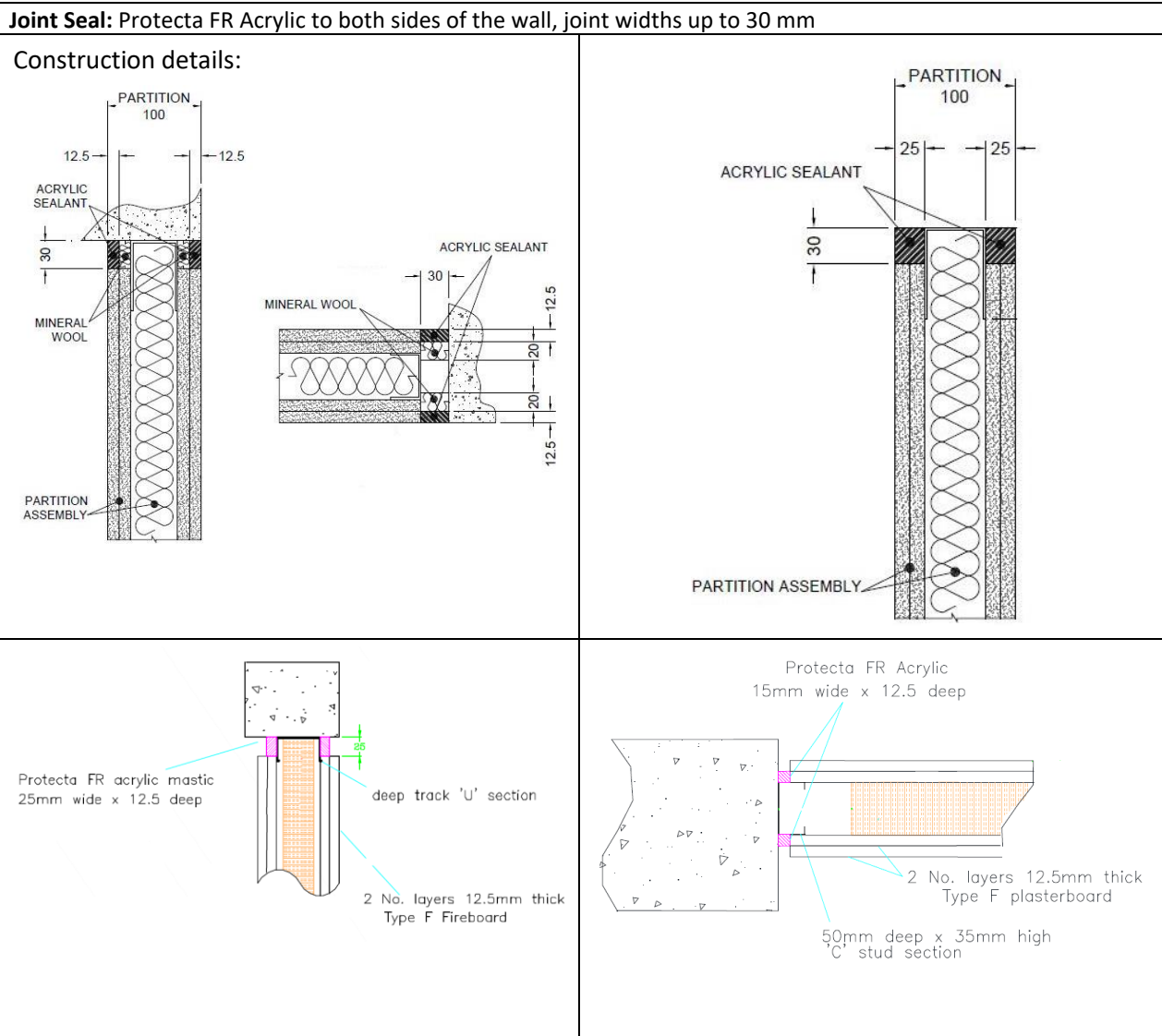

A.2.1.1

Substrate	Depth (mm)	Backing (minimum)	Classification
Plasterboard / concrete	12.5 min.	12.5 mm Stone wool 35 kg/m ³ plus 50 mm steel partition head track	EI 120 – T – X – F – W 30
		20 mm Stone wool 35 kg/m ³	EI 120 – V – X – F – W 30
	25 min.	50 mm steel partition head track /stud	EI 120 – T – X – F – W 30
	12.5 min.		EI 90 – T – X – F – W 25
			EI 90 – V – X – F – W 15

A.2.2 Flexible or rigid wall construction with wall thickness of minimum 100 mm and timber substrates and architraves

A.2.2.1 Linear joint or gap seals, vertically or horizontal orientated with backing materials

Joint Seal: Protecta FR Acrylic to one side of the wall, joint widths up to 30 mm

Construction details:

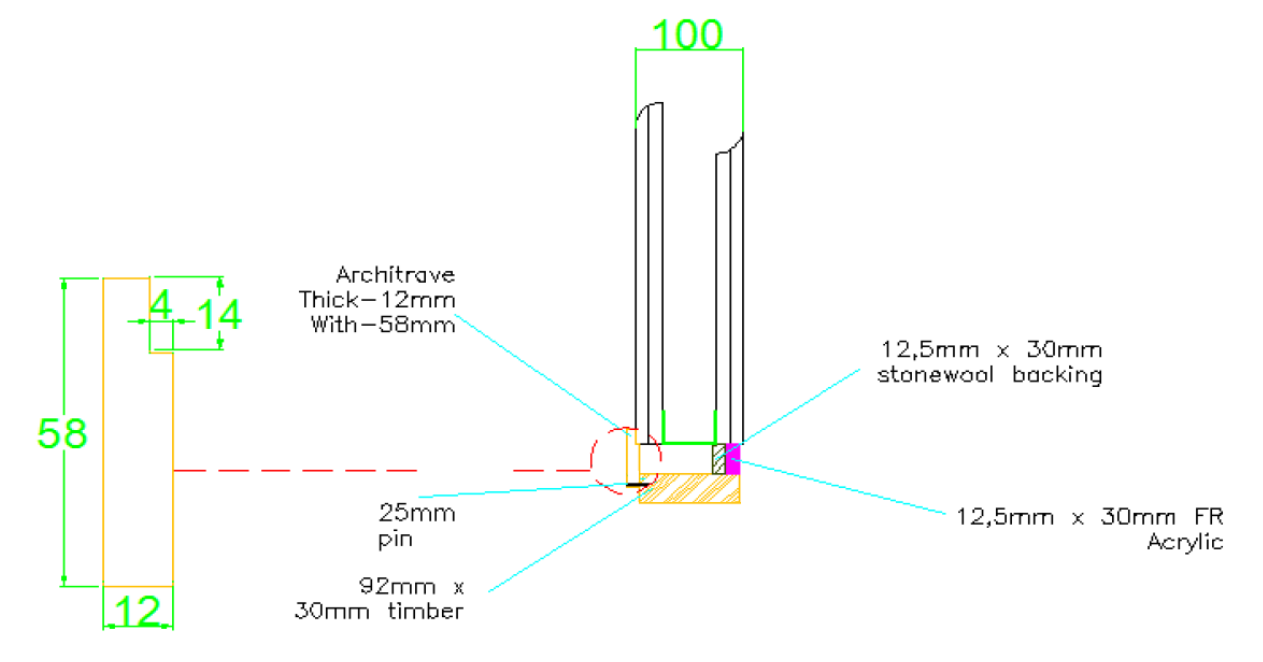

A.2.2.2

Substrate	Depth (mm)	Facing (minimum)	Backing	Classification
Flexible or rigid wall / Timber	12.5 min.	Single sided linear seals in flexible or rigid walls against wooden frames covered with architraves on the other side fixed with 25 mm steel pins at nominal 300 mm centres.	Stonewool, 12.5 mm deep min. 35 kg/m ³	EI 60 – V – X – F – W 30
				EI 60 – T – X – F – W 30

A.2.3 Flexible or rigid wall construction with wall thickness of minimum 100 mm and timber substrates

A.2.3.1 Linear joint or gap seals, vertically or horizontal orientated with backing materials

Joint Seal: Protecta FR Acrylic to both sides of the wall, joint widths up to 30 mm

Construction details:

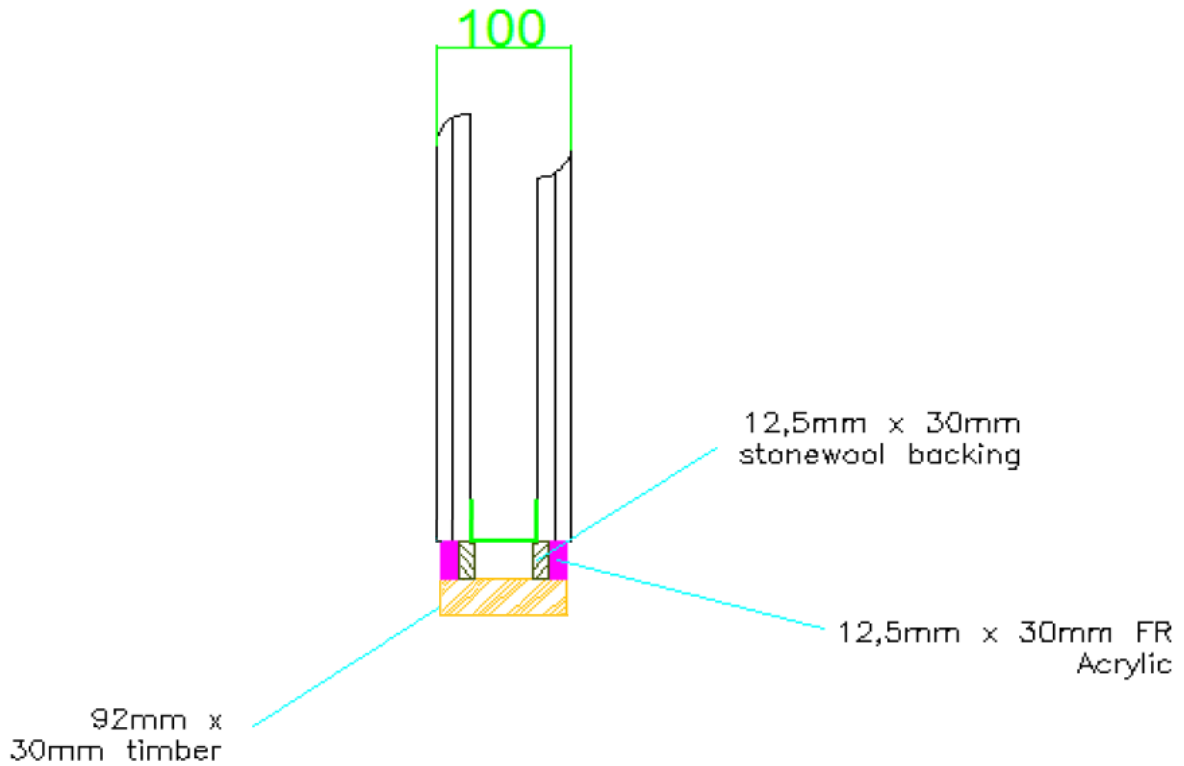

A.2.3.2

Substrate	Depth (mm)	Backing	Classification
Flexible or rigid wall / Timber	12.5 min.	Stonewool, 12.5 mm deep min. 35 kg/m ³	E 90 – V – X – F – W 30
			EI 60 – V – X – F – W 30
Flexible or rigid wall / Timber	12.5 min.	Stonewool, 12.5 mm deep min. 35 kg/m ³	E 90 – T – X – F – W 30
			EI 60 – T – X – F – W 30

A.2.4 Flexible or rigid wall construction with wall thickness of minimum 100 mm and steel substrates

A.2.4.1 Linear joint or gap seals, vertically or horizontal orientated with backing materials

Joint Seal: Protecta FR Acrylic to one side of the wall, with joint widths up to 30 mm.

Construction details:

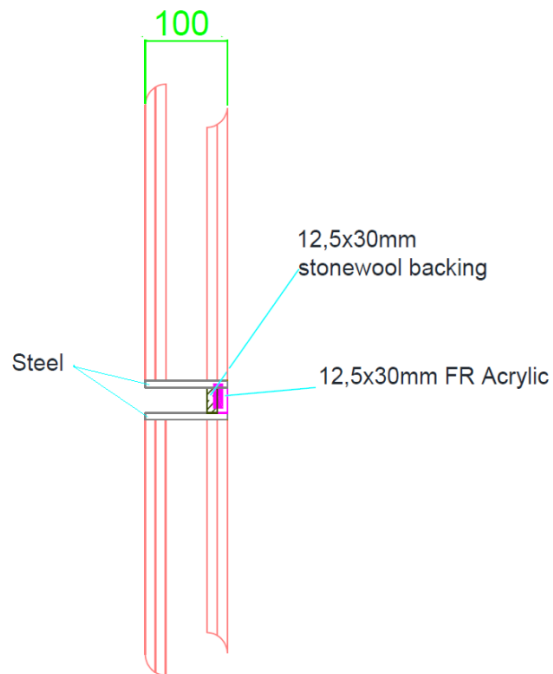

A.2.4.2

Substrate	Depth (mm)	Backing	Classification
Steel / steel	12.5 min.	Stonewool, 12.5 mm deep min. 35 kg/m ³	E 120 – V – X – F – W 30
			EI 30 – V – X – F – W 30
Steel / steel	12.5 min.	Stonewool, 12.5 mm deep min. 35 kg/m ³	E 120 – T – X – F – W 30
			EI 30 – T – X – F – W 30

A.2.5 Linear joint or gap seals, vertically or horizontal orientated with backing materials

Joint Seal: Protecta FR Acrylic to both sides of the wall, with joint widths up to 30 mm.

Construction details:

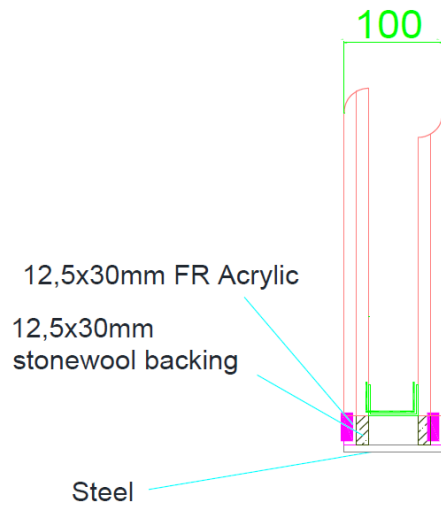

A.2.5.1

Substrate	Depth (mm)	Backing	Classification
Flexible or rigid wall / Steel	12.5 min.	Stonewool, 12.5 mm deep min. 35 kg/m ³	E 120 – V – X – F – W 30 ¹ EI 30 – V – X – F – W 30 ²
			E 120 – T – X – F – W 30 ³ EI 45 – T – X – F – W 30 ⁴

*Additional and for information only.

The classifications provided in Table A.2.5.1 consider the insulation performance of all components within the firestopping system as per the requirements of EN 1366-4. This includes temperature evaluation of the steel substrate.

In relation to each of the above classifications, temperatures recorded on the seal (exclusive of the supporting construction) exceeded the maximum allowable after the following times (rounded down):

¹ 120, ² 90, ³ 120, ⁴ 60

A.3 Rigid wall constructions according to 1.2.1 with wall thickness of minimum 150 mm

A.3.1 Linear joint or gap seal, between head of rigid wall and soffit of concrete floor / between rigid walls

Joint Seal: Protecta FR Acrylic to either side (or any position between) or both sides of the wall, joint widths up to 30 mm

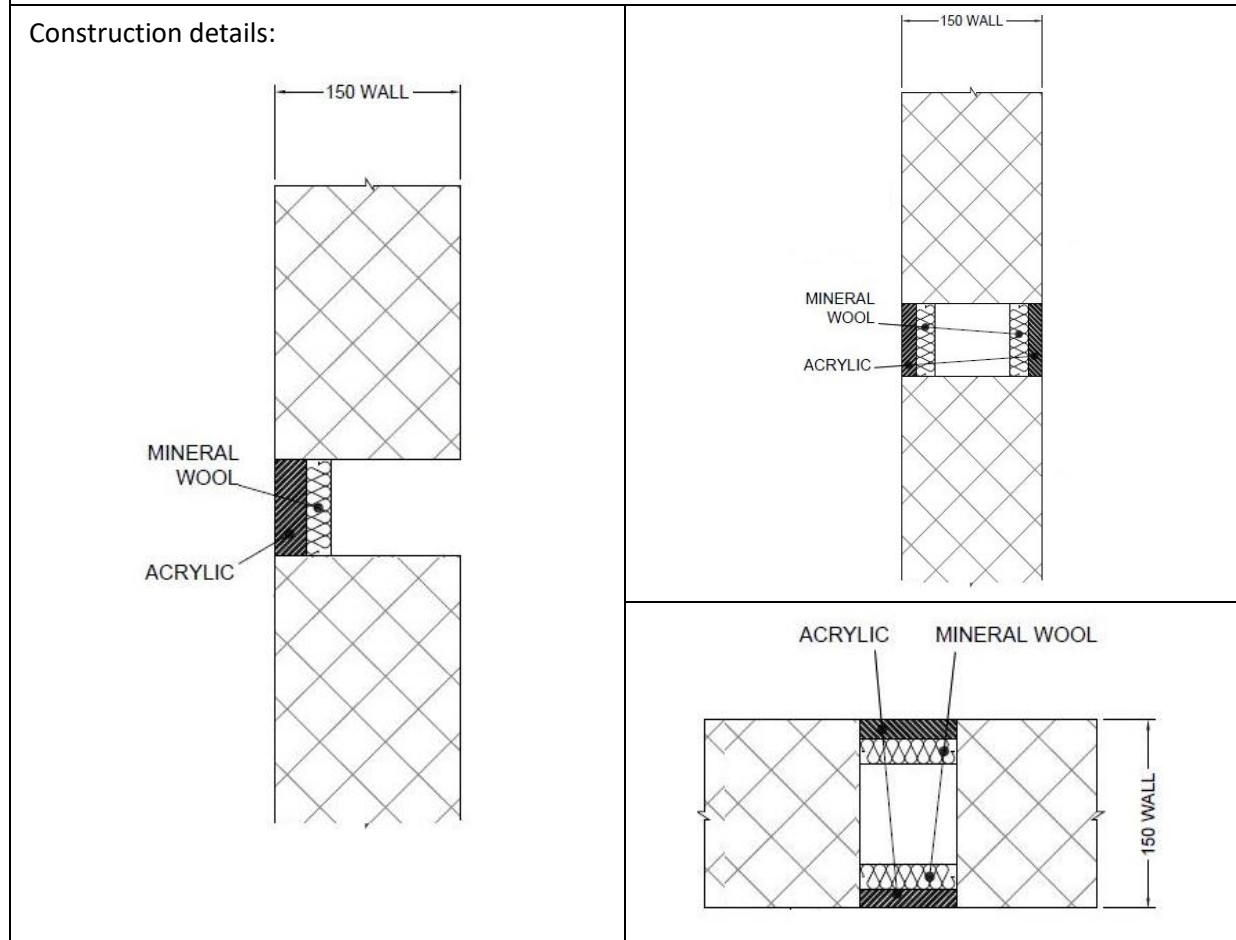

A.3.1.1

Substrate	Depth (mm)	Backing (minimum)	Classification
masonry/ concrete	25 min. (one side)	20 mm Stone wool 40 kg/m ³	E 240 – T – X – F – W 30 EI 60 – T – X – F – W 30
	15 min. (both sides)		EI 240 – V – X – F – W 30 EI 240 – T – X – F – W 30
	10 min. (one side)	60 mm Stone wool 33 kg/m ³	E 240 – T – X – F – W 50 EI 60 – T – X – F – W 50 EI 120 – V – X – F – W 50
	25 min. (one side)	48 mm Protecta Mineral Fibre BIO	E 240 – T – X – F – W 30 EI 120 – T – X – F – W 30

A.4 Rigid floor constructions according to 1.2.1 with floor thickness of minimum 150 mm

A.4.1 Linear joint or gap seal, between floor slabs or between floor slab and wall with sealant to the top face of the floor only

Joint Seal: Protecta FR Acrylic to either side (or any position between) or both sides of the floor, joint widths up to 100 mm

Construction details:

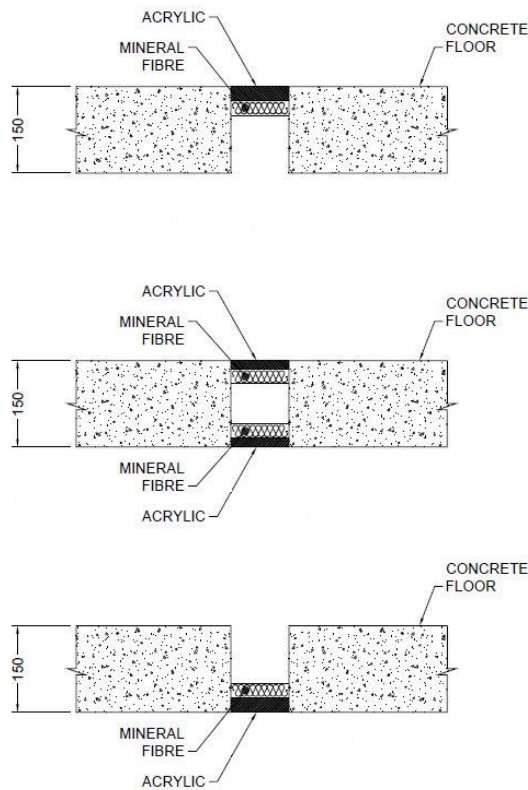

A.4.1.1

Substrate	Depth (mm)	Backing (minimum)	Classification
masonry/ concrete	25 min. (any position)	25 mm Protecta Mineral Fibre BIO	E 120 – H – X – F – W 100 EI 60 – H – X – F – W 100
	25 min (top face)		EI 180 – H – X – F – W 100
	15 min. (both sides)	25 mm Stone wool 40 kg/m ³	EI 120 – H – X – F – W 100
		25 mm Stone wool 140 kg/m ³	EI 180 – H – X – F – W 100
	15 min. (both sides)	25 mm stone wool 35 kg/m ³ insulation	EI 240 – H – X – F – W 30
	10 min. (top face)	90 mm Stone wool 33 kg/m ³	EI 240 – H – X – F – W 100

A.4.2 Linear joint or gap seals, in or between rigid floors

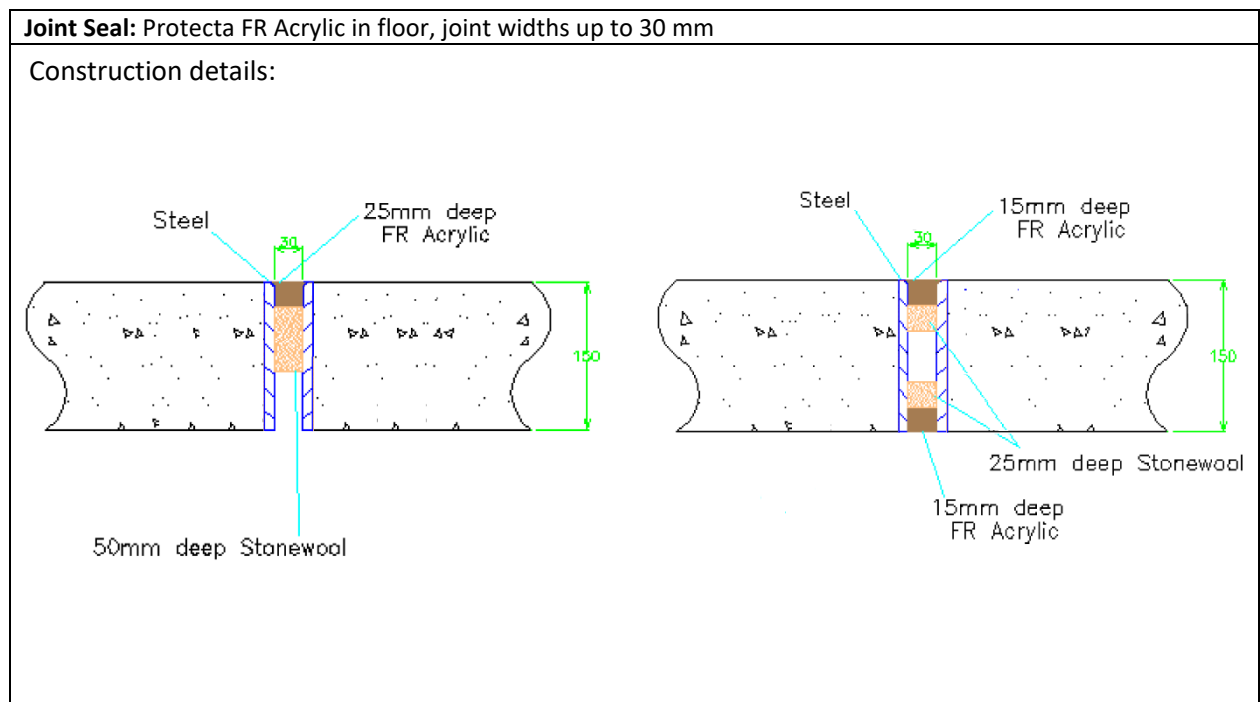

A.4.2.1

Substrate	Depth (mm)	Backing	Position	Classification
Steel/ steel or Steel/ concrete	25 min.	Stonewool, 50 mm deep min. 35 kg/m ³	Top	E 240 – H – X – F – W 30¹ EI 30 – H – X – F – W 30²
	15 min.	Stonewool, 25 mm deep min. 35 kg/m ³	Both	E 240 – H – X – F – W 30³ EI 45 – H – X – F – W 30⁴
Aluminium / concrete	25 min.	Stonewool, 50 mm deep min. 35 kg/m ³	Top	E 180 – H – X – F – W 30⁵ EI 20 – H – X – F – W 30⁶

*Additional and for information only.

The classifications provided in Table A.4.2.1 consider the insulation performance of all components within the firestopping system as per the requirements of EN 1366-4. This includes temperature evaluation of the steel substrate.

In relation to each of the above classifications, temperatures recorded on the seal (exclusive of the supporting construction) exceeded the maximum allowable after the following times (rounded down):

¹ 240, ² 60, ³ 240, ⁴ 120, ⁵ 180, ⁶ 60